

INSTRUCTION BOOKLET FOR

AIR FEEDS



200 Circuit Drive • North Kingstown, Rhode Island 02852 • USA
International Phone: 401-781-7800 • Toll Free: 800-338-7268 • Fax: 401-738-2586 •
• Internet Address: www.durantco.com •

ATTENTION: PLANT MANAGER

Thank you for purchasing Durant equipment. Enclosed are very important safety instructions, operating instructions, and setup procedures.

Read all these materials completely and carefully. Please distribute copies to your SAFETY MANAGER, PRODUCTION MANAGER, and MACHINE OPERATORS.

If there is any help required in setup or operation, we will be readily available for your assistance.

Thank you again and we look forward to developing and maintaining a fine relationship with your company.

Sincerely,

DURANT TOOL COMPANY

SAFETY INSTRUCTIONS FOR ALL DURANT EQUIPMENT

The enclosed information and instructions must be forwarded and distributed to the Plant Safety Director, Plant Manager, Production Manager, and all Operators of Durant equipment.

Operators of Durant equipment must have a minimum of (3) three years operating experience with similar Durant press room equipment or a minimum of (3) three years experience with identical equipment manufactured by other press room equipment manufacturers.

WARNING

Never operate, install, or maintain this machine without understanding the complete and safe operation thereof.

It is the employer's responsibility to provide proper safety devices and equipment to safeguard the operator from harm and to safeguard this machine at all times to meet all current government safety codes and standards.

CAUTION

All Durant equipment must be securely fastened to the floor. This will prevent the machine from tipping. Failure to follow the above instructions could cause harm to the operator or machine.

ATTENTION

If any danger points are observed:

1. Immediately stop machine.
2. Do not run machine until danger point is eliminated.
3. Report danger point in writing to your employer.
4. Keep a copy of your report for your records.
5. Do not run machine again until danger point has been corrected.
6. It is your employer's responsibility to safeguard this machine to meet all government safety codes and standards.
7. There are U.S. companies that specifically specialize in safe guarding machines to plant requirements and government codes. The safe guarding companies are located throughout the United States, Canada, and foreign countries. Representatives will visit your site to advise and recommend safe guarding procedures for your company.

IMPORTANT

Before the first use and monthly thereafter, all nuts, screws, and bolts should be checked for tightness. Gears, sprockets, chains, and belts should also be checked for tightness.

Grease and oil fittings and reducers monthly.

DURANT / HERRBLITZ pneumatic feeder was produced to feed automatically strips and wires, for pressings and/or mechanical functions that require stroked feed elements.

The Durant/Herrblitz feeder may be mounted:

- a) **Directly on the die:** Feed entry into the die (pushing strip) or feed exit from the die (pulling strip). As in this case the feeder is very near to the matrix of the die, all the problems of strip bending are avoided, specially with thin and delicate strips.
- b) **On the press or another machine** through a bracket or a square. Also in this case it may be mounted feed entry into the press (pushing strip) or feed exit from the press (pulling strip).

1- FEED ENTRY INTO THE DIE (PUSHING STRIP)

Install a plate between the base of the die and the feeder to allow realignment in the vertical plane after resharpening the blanking-tool (fig. 1).

This plate should not exceed the size of the main body of the feeder otherwise movement of the feeder clamp will be restricted. Always adjust for perfect alignment between the feeder and the strip sliding plane (fig. 2-2A).

1A-FEED EXIT FROM THE DIE (PULLING STRIP)

Picture 3 is an example of a pulling application.

Attention: the feed clamp must have the possibility to move freely backwards and down. It is advisable to use a pneumatic or an electric control through a cam.

2-FEEDER MOUNTED ON THE PRESS

When the feeder has to be installed on the press and/or on the operating machine, normally a mounting bracket (see fig. 4) is required, directly fitted on the press table. For our heavy-duty series feeders, we have a special bracket (fig. 4A) which is adjustable with screws both for height and the direction of the strip feed. On demand we can supply an appropriate bracket to mount feeders exit from the press (pulling strip).

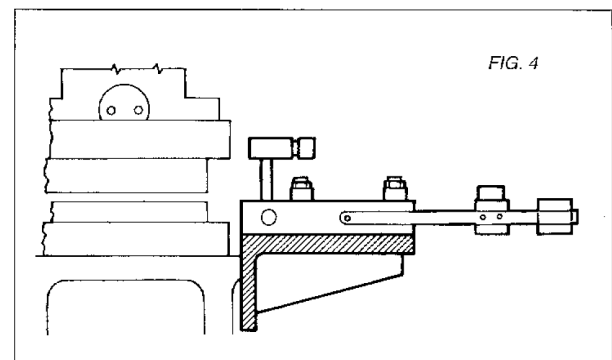
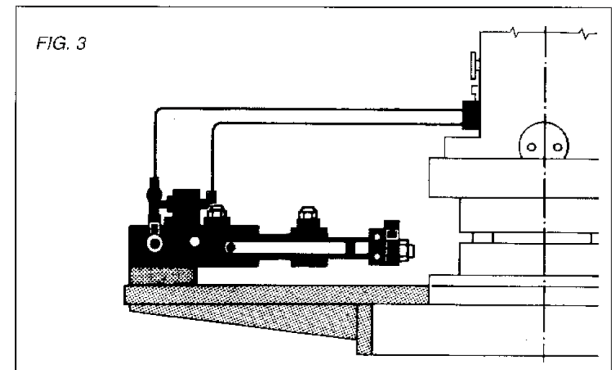
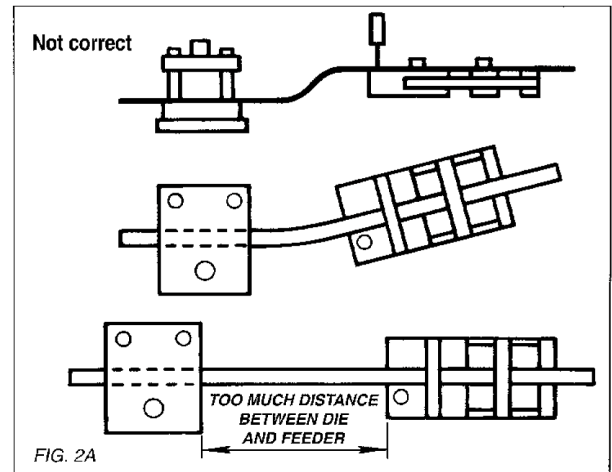
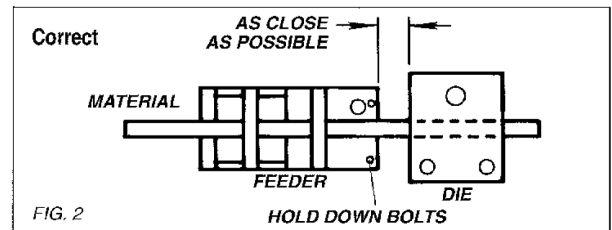
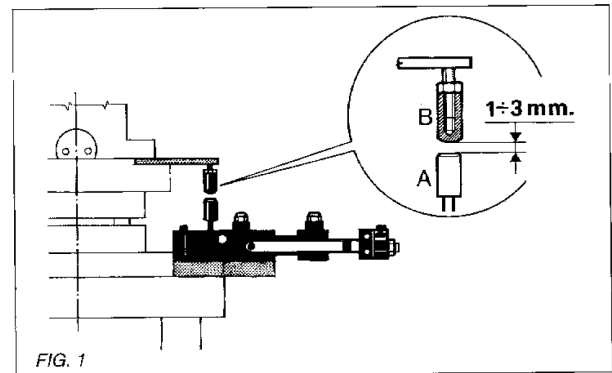
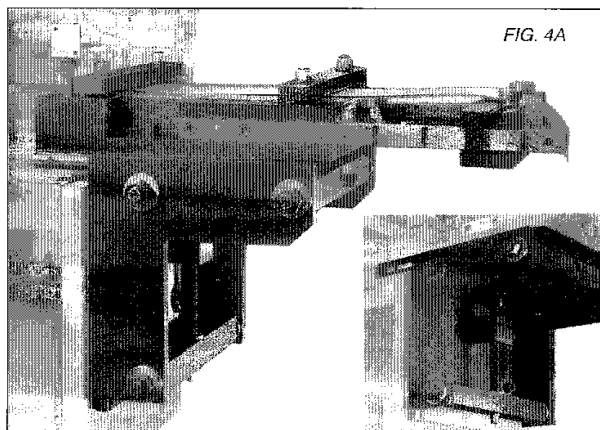

PUTTING INTO SERVICE

Important note: The pneumatic and electric connection of the feeder, and the mechanical linking must always be securely locked and isolated from the control panel of the machine in the work place.

The whole installation must conform to the dispositions UNI-EN and to the Machines Directives 89/392/CEE; 73/23/CEE and to the EN 292-1; En 50204-1.

3- MOUNTING OF THE FEEDER ON THE DIE OR OPERATING MACHINE.

The fastening of the feeder on the die or on the bracket needs 2 or 4 screws (heavy models) (fig. 5).

Important note: it is necessary to assemble when the machine emergency block is SWITCHED ON.

4-AIR POWER SUPPLY AND LUBRICATION

Important note: the following operations have to be made when the machine emergency block is SWITCHED ON.

Compressed air must be filtered and dehumidified. Operating pressure: 4-8 Bar (fig. 6). We suggest to provide the small feeders with a small size lubricator (1/4 gas fitting) as at low air consumption, the medium and large size lubricators are inefficient. Use oil for pneumatic lubrication, (hydraulic oil) type ISO VG 22. Do not use spindle oils, motor oils or solvents. Use of these types of oils will cause feed performance to deteriorate, as well as premature wear. Regulate the lubricator so that it supplies a drop every 50-60 seconds approximately.

IMPORTANT NOTE: OPERATIONS TO BE DONE AT SHIFT BEGINNING

- CONTROL OF THE LEVEL OF THE LUBRICATING OIL IN THE BOWL OF THE LUBRICATOR
- LUBRICATION OF THE GUIDES WITH EXPENDABLE MACHINE OIL

To facilitate the insertion of the strip on the feeder, it is preferable to install a 3-way exhaust valve on the feeder, which stops the air supply and discharges the feeder air at the same time (fig. 6A)

Compressed air entry is located on the side of the feeder in the types A-B-C; BX; CX; DX; P-S-Z (fig. 7), and under the block in the types SX; ZX; TZ; V; 2TV; K; 2TK (fig. 7A).

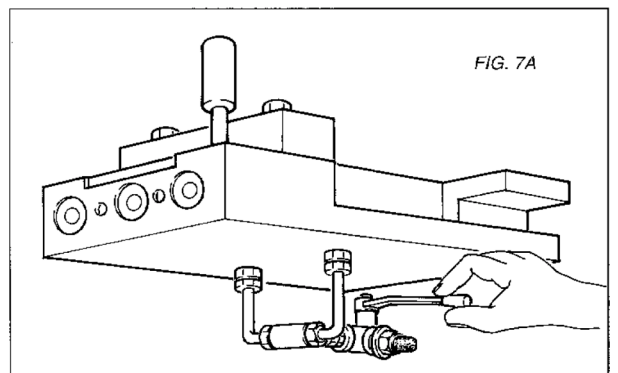
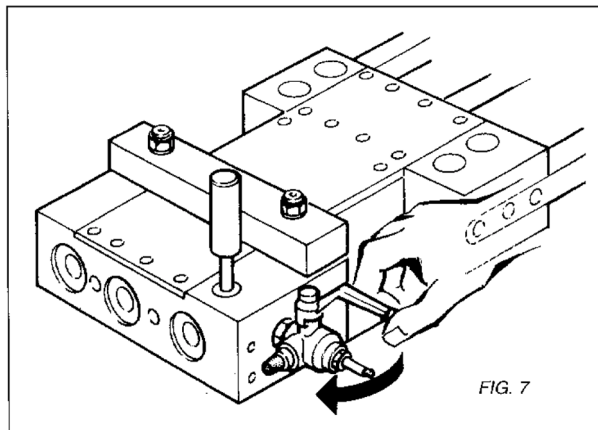
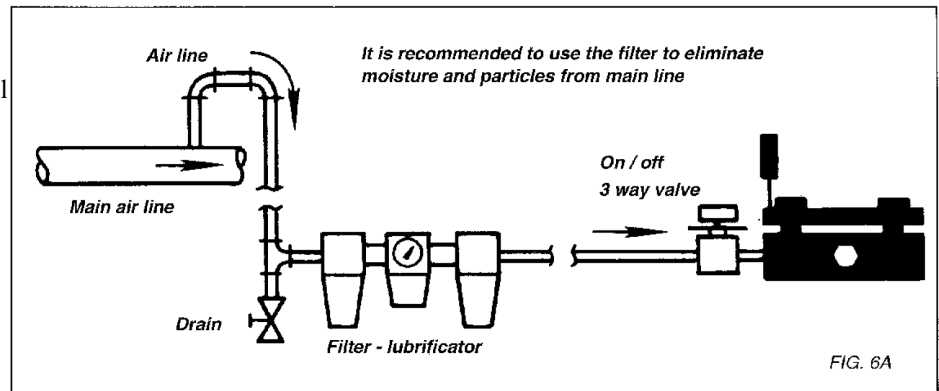
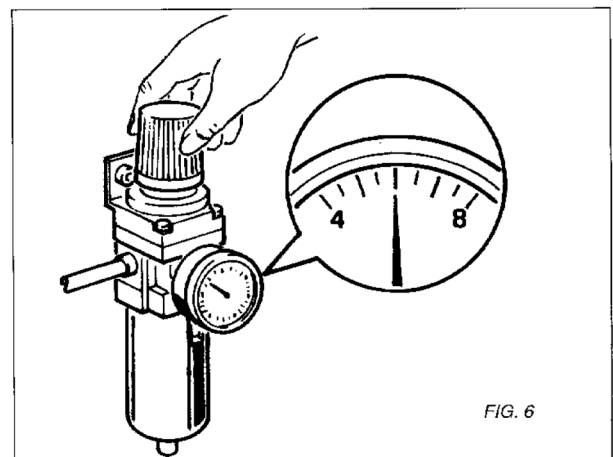
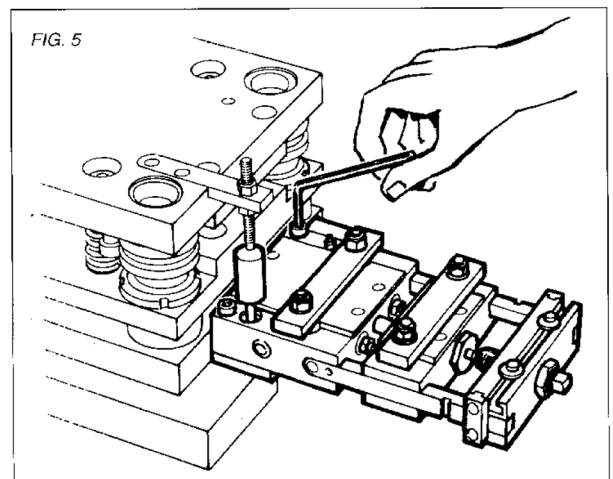

5-FEEDER ACTUATING

Herrblitz feeders may be operated in the following ways:

5A-FEEDER OPERATING BY MECHANICAL ACTUATION

The reciprocating movement of the press and/or of the die is transmitted to the control valve A through an adjustable plunger (B) mounted on the ram of the press or on the upper die block (fig. 1).

It is advisable to use this actuation system in case of a minimum vertical stroke of the press

(30-40mm). When the press is at the top of dead centre and the air inserted in the feeder, the distance between plunger B and valve A must be between 1 and 3 mm.

Table 8 will define the clearance between plunger B and valve A relating to the press-stroke and type of feeder. With long vertical strokes of the press (see the heavy type written values), it is recommended to use, instead of the mechanical valve, the electrical or the pneumatical remote actuation. Plunger B should contact the center of valve A stem.

Important note: these adjustment operations must be made when the machine emergency block is SWITCHED ON.

5B-AIR FEED SEQUENCES (fig. 9)

A) Press at Top Dead Centre:

- mechanical valve up
- stock clamp is open
- mobile clamp is closed and forward

B) During press downstroke:

- mechanical valve is actuated
- stock clamp closes
- feed clamp opens
- feed clamp goes back

C) Press at Bottom Dead Centre:

- mechanical valve is actuated
- stock clamp is closed
- mobile clamp is open
- feed clamp has finished its backstroke

D) During press upstroke:

- mechanical valve is coming up
- stock clamp opens
- feed clamp closes
- strip feeding begins

Press stroke (mm)	Clearance between plunger and valve		
	TYPE A-B-C	TYPE BX-CX-DX	TYPE P-S-Z
0-6	0,5	0,5	—
7-10	1-3	1-3	1-3
11-15	1-3	1-3	1-3
16-20	1-3	1-3	1-3
21-25	1-3	1-3	1-3
26-30	4-7	1-3	1-3
31-38	12-15	1-3	1-3
39-50	24-27	11-14	1-3
51-60	34-37	21-24	8-11
61-70	44-47	31-34	18-21
71-80	54-57	41-44	28-31
81-90	64-67	51-54	38-41
91-100	74-77	61-64	48-51

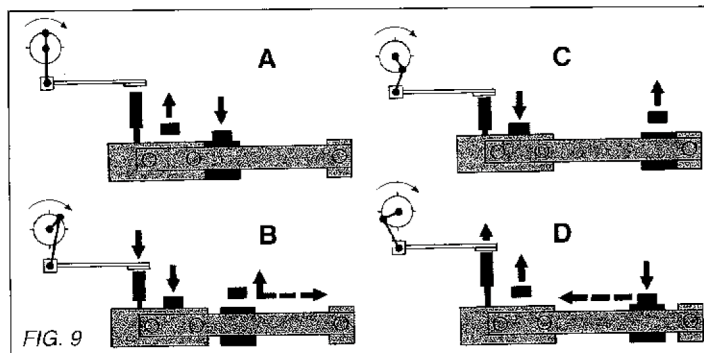

5C-FEEDER OPERATING BY ELECTRICAL OR PNEUMATICAL REMOTE ACTUATION

If the press work requires very long ram-strokes, i.e. for deep drawing, or if it is necessary to feed at a precise moment during the rotary press cycle (e.g. because of long pilots), or if two or more synchronized feeders have to be coupled, then it is necessary to employ a remote control (pneumatic or electropneumatic) actuated by a circular or linear cam (fig. 10-11-12-13).

PNEUMATIC CONTROL CONNECTION SCHEME

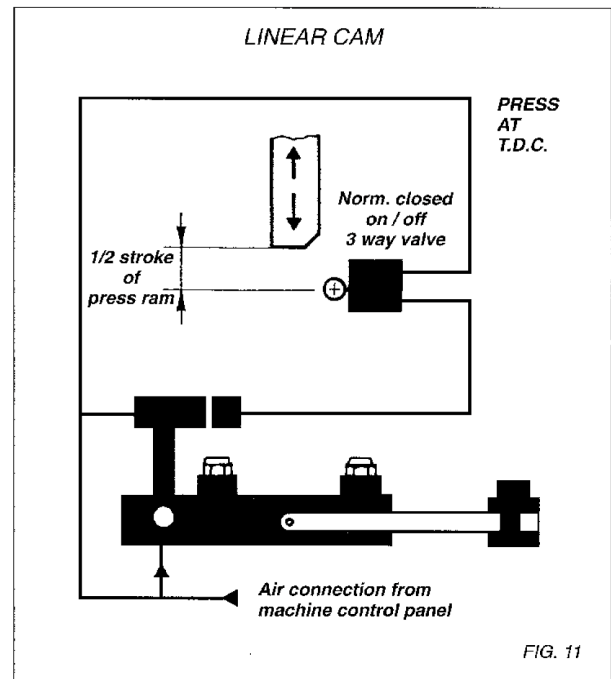
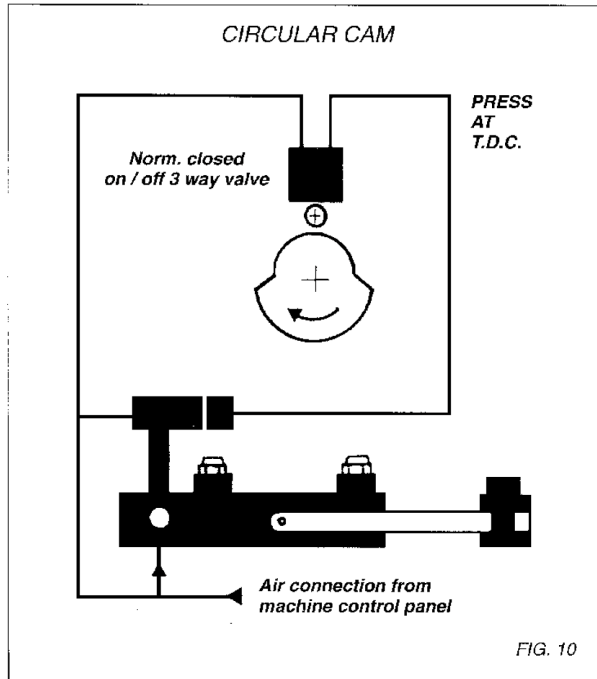

The following voltages are available:

24V/50Hz-24V/60Hz-110V/50Hz-120V/60Hz-220V/50Hz-240V/60 Hz-24 VDC

Important note: connect with machine emergency block SWITCHED ON.

ELECTRIC CONTROL CONNECTION SCHEME

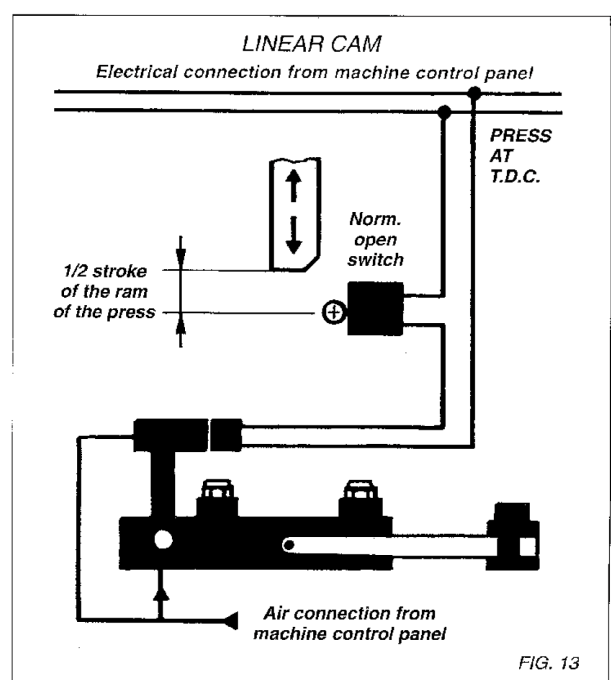
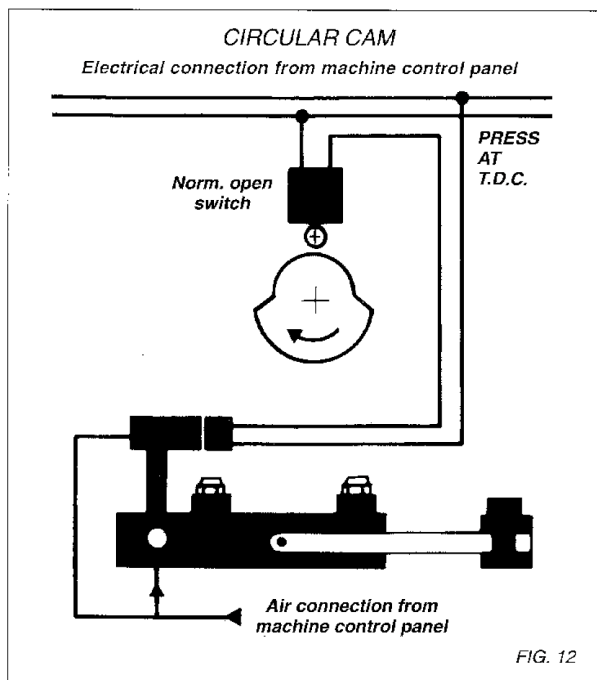

6- SHAPE AND ADJUSTMENT OF THE CIRCULAR CAM FOR REMOTE ACTUATION

The shape of the cam depends on the number of cycles pro min. and on the feed stroke.

To assist in preventing downtime, we can supply a cam with adjustable sector α and locking ring.

Herewith there is the working diagram on α lobe of the cam, in relation to the cycles pro min. of the press or working machine (fig. 14).

Lobe α determines the back-stroke time of the mobile clamp (not feeding time).

For a better indication of the feeding times we represented the cam as a clock (fig. 15) and we determined more or less the following sectors:

- from 8 to 12 begin of material feed cycle
- from 12 to 4 end of material feed cycle
- from 4 to 8 the mobile clamp goes back to take other material and the die makes the pressing.

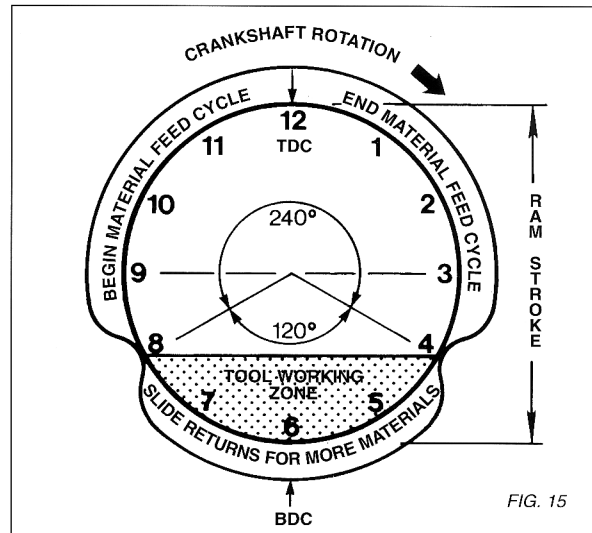
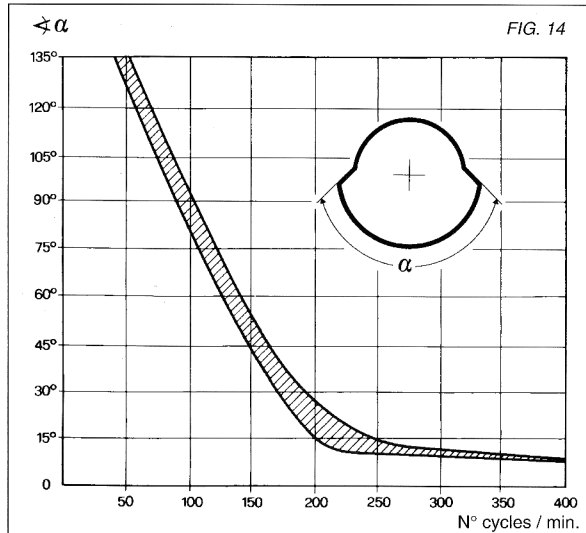

7- FEEDER OPERATING BY A REPEATER CONTROL SYSTEM.

The air feed can be multiple stroked for each cycle of the press to obtain greater feed length increments than the air feed's maximum feed stroke capacity.

Our repeater control (fig. 16) has a digital counter and its advantage is that it works through potentiometers, so it is not necessary to mount end strokes and electrical cables on the feeder.

Through potentiometer B it is possible to adjust the feeding speed of the mobile clamp in relation to the stroke length.

Through potentiometer C it is possible to balance the dwell of the clamp at the forward stroke-end and at the backward stroke-end.

Sector E connects and disconnects the repeater system:

- When it is disconnected (pos.MAN) the press works with endless cycle and controls the feeder.
- With the repeater system switched on (pos. AUT) the feeder controls the press, which works in single stroke sequence.

If we set number 1 on the display the feeder control the press and signals the downstroke. This "single stroke device", is used when the press speed is too high in relation to the feeding stroke of the feeder. Push button D starts the work-cycle.

Important note: The electrical connection of the repeater control system must always be securely locked and isolated from the control panel of the machine in the work-place. The whole installation must conform to the dispositions UNI-EN and to the directives 89/392/CEE; 73/23/CEE and to the EN 292-1; EN 50204-1.

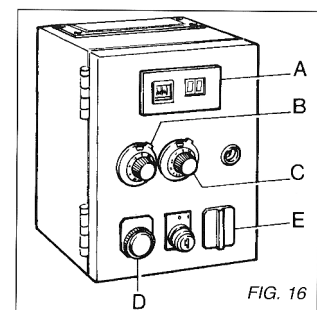

8- INSTALLING COUPLED FEEDERS (PUSH - PULL MOVEMENT TO FEED BARS, CROP ENDS, PROFILES)

Many applications function without feeding from coil.

In this case it is necessary to use two feeders with synchronized movement: (fig. 17)

- the first one, before the die or the machine, pushes the material into the die.
- the second one, after the die or the machine, pulls the material out of the die.

When the first feeder finished feeding material into the die and the second one takes control of the feed, it is possible, by means of a 3 way valve, to release air from the first feeder and enable new material to be inserted and allow operation of the press on continuous cycling.

Synchronized action is controlled by the electric valves on the feeders which are both operated by the same cam on the press.

It is also possible to synchronize them mechanically, by connecting both feed - clamps with a light alloy rod.

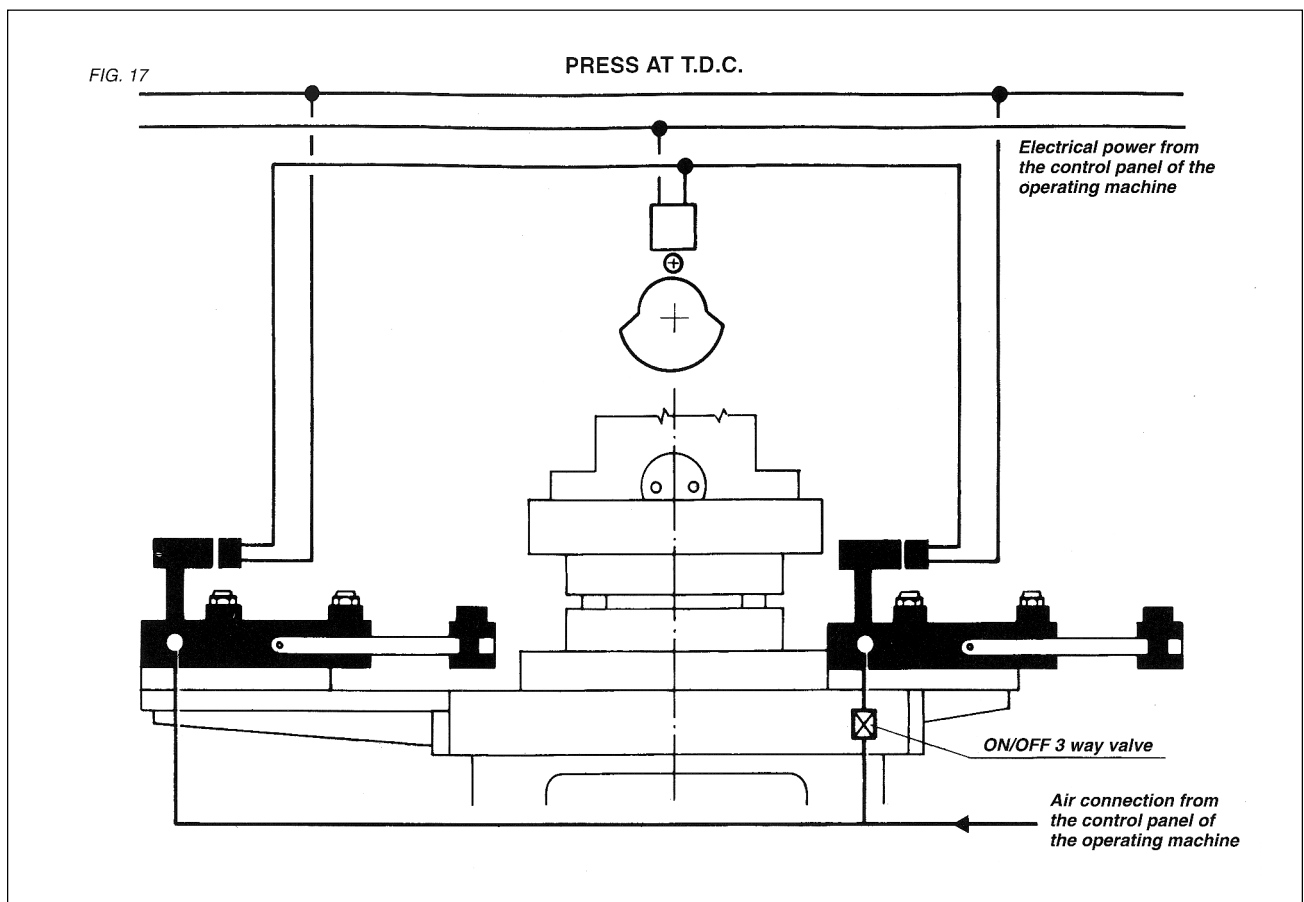

9- STOCK CLAMP OPENING FOR PILOT RELEASE

The cheapest system is to replace the stock clamp of the feeder with a spring clamp (fig. 18).

Turn the hex nut to compress the spring for the desired clamp material pressure. So the strip may be slightly adjusted by the pilots.

For most pilot release applications, set the feed pitch approx. mm 0.1 shorter than required and the pilot release stock clamp will allow the pilot pin to pull the material under the clamp pad into the proper position.

For a complete opening of the stock clamp during the pilots centering, two solutions are available:

a) An additional electricvalve (fig .19) on the feed block (internal pilot release).

This additional valve, actuated by a cam, opens the stock clamp when desired.

Included parts are:

- the cam to control the electricvalve of the feeder
- the cam to control the electricvalve of the clamp
- the two proximities to be installed on the cams
- an electrostatic device to coordinated the two electricvalves

With this system, the stock clamp is not made heavy and replies quickly to the opening and closing signals.

b) Electropneumatic clamp pilots (fig. 20).

The clamp pad is fitted with a quick response cylinder for positive stock grip and release.

Timing is controlled by an external 4-way valve.

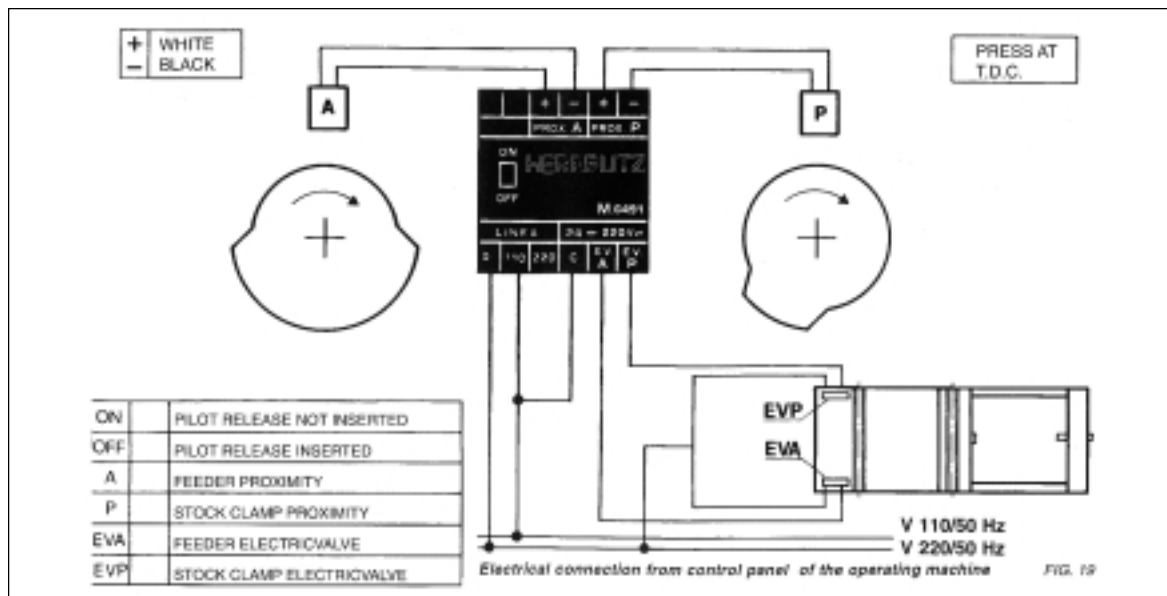
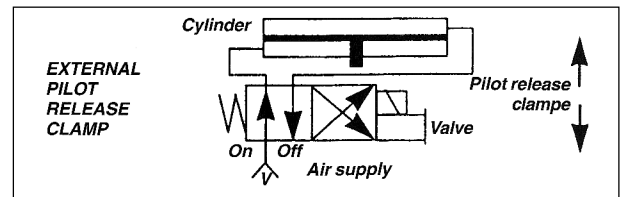
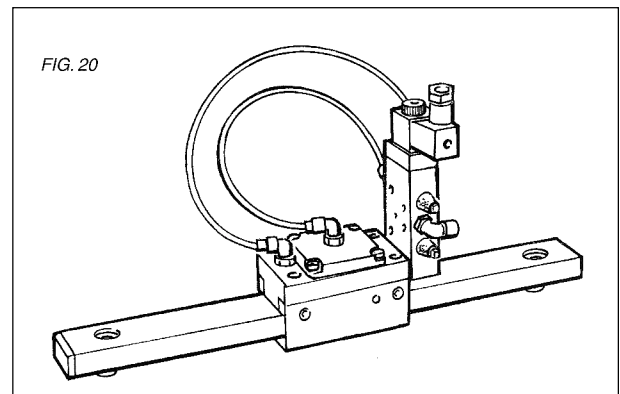
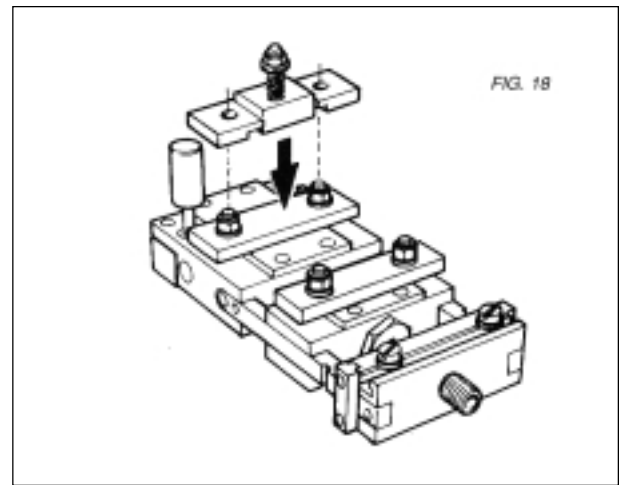

10- STROKE ADJUSTMENT

Important note: *The adjusting operations must be made when machine emergency block is switched on.*

- a) It is necessary to position the stop block for the most suitable feed length by reference to the milled cut outs on the slider guide pieces.
- b) Through the fine pitch screw (part 46) and with the air discharged, it is possible to adjust the feeder's stroke, inserting adjuster blocks between the screw and the rear shock absorber (fig. 21).

Necessary tools:

Types A-B-C; BX; DX; SX; ZX; wrench mm.28; allen wrench mm.8

Types P-S-TZ; V-K; 2TV; 2TK; wrench mm. 32; allen wrench mm.8

On feeders with 3 rear shock-absorbers and 3 screws, the stroke adjustment is made by adjusting the middle screw (fig. 22).

The two lateral adjustment screws can be backed off from the middle screw setting to overcome the possibility of reducing clamp speed at the end of the stroke.

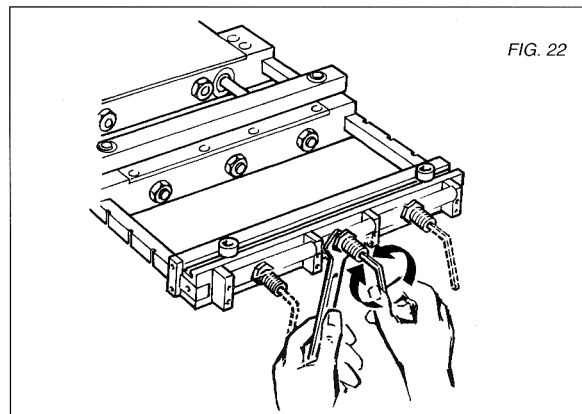
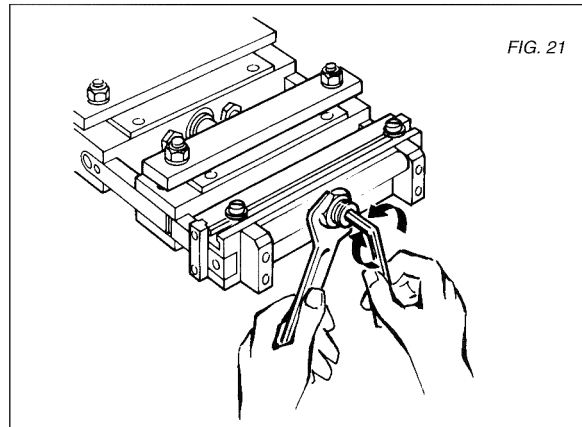

11- FEED SPEED ADJUSTMENT

Important note: *The adjusting operations must be made when machine emergency block is switched on.*

Note that, with strips of the max. size as per limits of feeder's performances, it is necessary to open the exhaust valve fully, whereas with light strips it is advisable to reduce the speed of the feeder to match the requirements of the press (fig. 23-24-25-26). The slower the feed of the strip, the more precise the stroke.

Necessary tools;

Type A-B-C; BX; CX; DX; wrench mm. 8; allen wrench mm. 2,5

Type V-K; TZ; 2TV; 2TK; wrench mm. 17; allen wrench mm.5

On types V-K, TZ, 2TV, 2TK there are 2 adjusting screws, one on each side. Screw first one of them completely, and then adjust the other one.

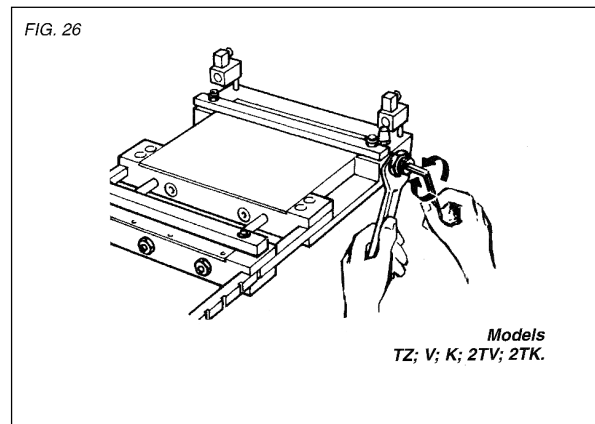
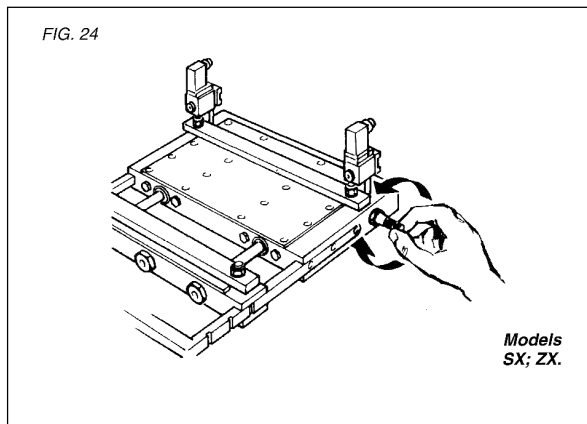
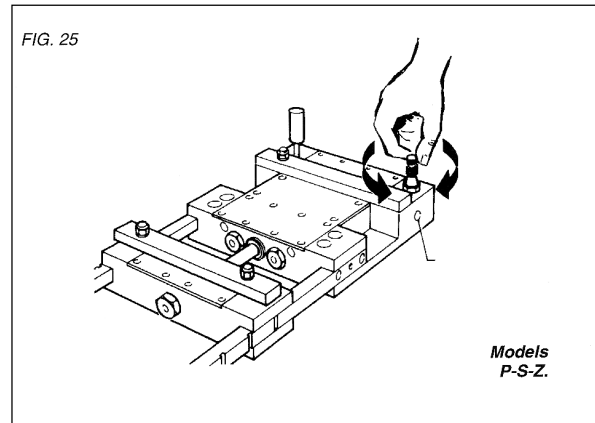
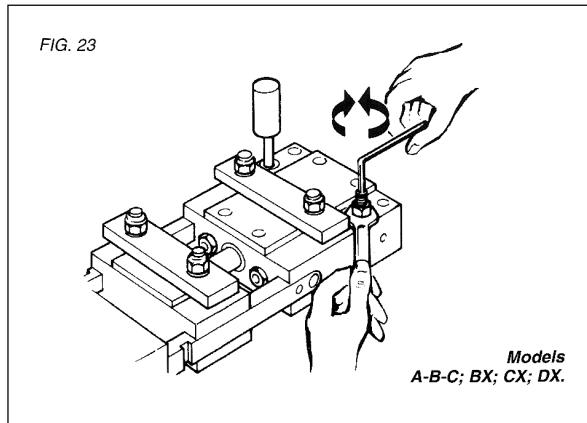

USE IN SERVICE

To correctly use Durant/Herrblitz feeders it is essential to carry out:

- correct putting into service.
- the periodical maintenance as indicated.

Full attention must be given to the installation and protection of all guarding.

Important note: *The adjusting operations must be made when machine emergency block is switched on.*

See point 10: feed stroke adjustment

See point 11: feed speed adjustment

See point 6: cams adjustment

Full attention must be given to the installation and protection of all guarding.

MAINTENANCE

Important note: The following operations must be made with machine emergency block SWITCHED ON.

Recommendation: **All the maintenance operations must be made by qualified and skilled operators.** The aim of the maintenance operations is to restore and preserve the machines in work conditions, as stated in our operation and maintenance book. **It is important to pay considerable attention to verify that the whole of the complex installation is in order, and that which is stated in the dispositions CE and UNI-EN 292-1; 292-2; EN 50204-1 is complied with.**

12-PERIODICAL MAINTENANCE

Every year check the condition of the main seals mounted on the components of the feeder, replace those that are worn out, following the Herrblitz feeders components table. **Preventive and scheduled maintenance to avoid breakdowns.** The use of our feeder under different conditions from those stated in this catalogue may cause power losses, air leaks and/or several working anomalies. These problems may be solved with a program of inspection and maintenance as indicated in the table for the solution of possible working defects.

TABLE FOR SOLUTION OF WORKING DEFECTS

TABLE FOR SOLUTION OF WORKING DEFECTS

AIR LEAK	MECHANICAL ANOMALIES	Probable o-ring to be replaced (see spare-parts table)					Probable mechanical parts to be replaced (see spare-parts table)			
From exhaust hole pos. 1	With air connected and without actuating the control, the feed clamp slides to the stop bar.	64 b	68 c	69 d	61 e	65 g	8 a	6 f		
From hole pos. 2	The feeder does not work and does not end the feeding stroke	62 b	63 a				7 c	6 d		
From exhaust hole pos. 3 (also actuating the standard control or the remote-control).	The feeder does not work.	82 a	73 b	75 c			19 d	26 e	22 f	23 g
From exhaust hole pos. 3 (actuating the standard control or the remote-control air leak stops).	The feeder does not work.	73 a					22 b	23 c		
	Actuating the standard control or the remote control, the feeder does not work. Only the clamps open and close	63 b	62 c				7 a	6 d		

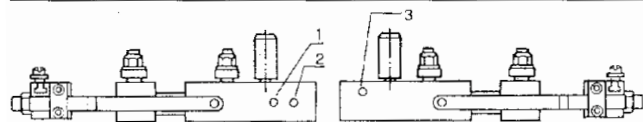

The letters of alphabet inserted in the boxes of the table indicate the substitutions in priority. The biggest probability is indicated by “a” and in decreasing order by “b-c” etc.

ASSEMBLING AND DISASSEMBLING OPERATIONS

Attention: *The following operations must be made with machine emergency block switched on.*

The ASSEMBLING and the DISASSEMBLING operations must be made by qualified and expert operations. They must do exactly what is written in these instructions (putting into service and maintenance).

The operator must pay attention that the work is done to the best standard and following the directives 89/392/CEE; 91/368/CEE; 73/23/CEE; 292-1; EN 50204-1.

MAIN MAINTENANCE OPERATIONS

13- ASSEMBLING AND DISASSEMBLING OF THE STOCK CLAMP AND OF THE FEED CLAMP

For this operation it is necessary to insert an allen wrench as in fig. 27, to avoid the turning of the pistons, while screwing or unscrewing the respective nut.

Type A-B-C allen wrench mm. 3,5 - wrench mm. 13

Type BX; CX; DX; SX; ZX: allen wrench mm. 3,5 - wrench mm. 17

Type P-S-Z; TZ; V-K; 2TV: 2TK: allen wrench mm. 5 - wrench mm. 19

The clamp must always be screwed on the pistons, without tightening the nuts too much (these are self-locking nuts).

To increase the vertical opening of the two clamps, it is sufficient to insert washers between the clamps and the pistons (fig. 28).

In fact, there must be a vertical clearance of mm. 0,5 between the clamps and the strip.

The standard openings of the clamps are:

Types A-B-C mm. 1,5

Types BX; CX; DX; SX; ZX mm. 3

Types P-S-Z; TZ; V-K mm.6

For a good working, it is necessary that the two clamps are parallel to the lower sliding plates (fig.29).

The strip must be straight and perfectly aligned from the entrance in the feeder to the die.

Always adjust the roller stock guides with enough lateral clearance for camber and variations in stock width (fig. 30-31).

It is possible to modify the clamps to the profiles and shaped material, always paying attention to have a level clamp condition for both the feed clamp and stock clamp (fig. 32-33).

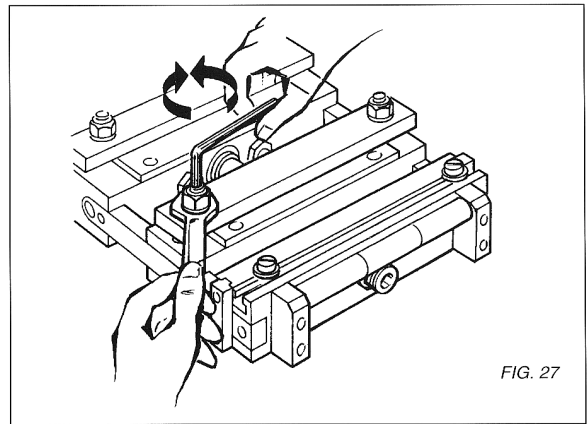

FIG. 27

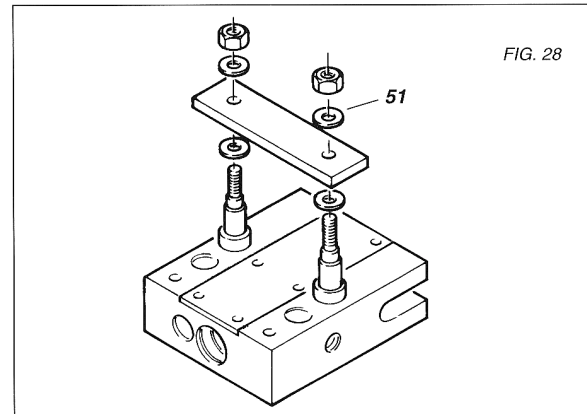

FIG. 28

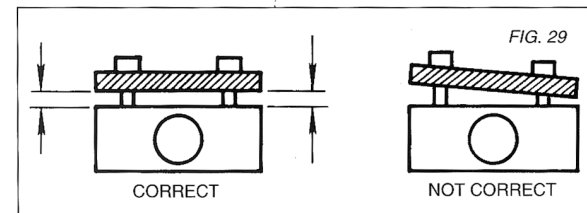

FIG. 29

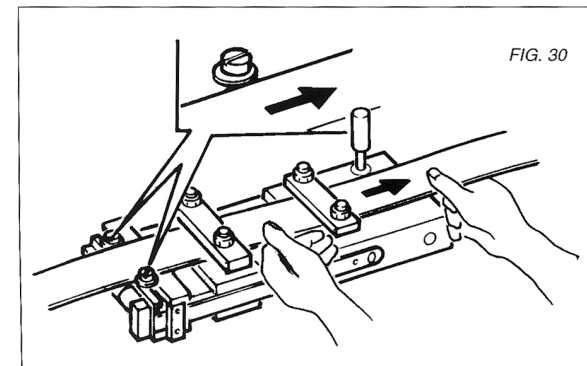

FIG. 30

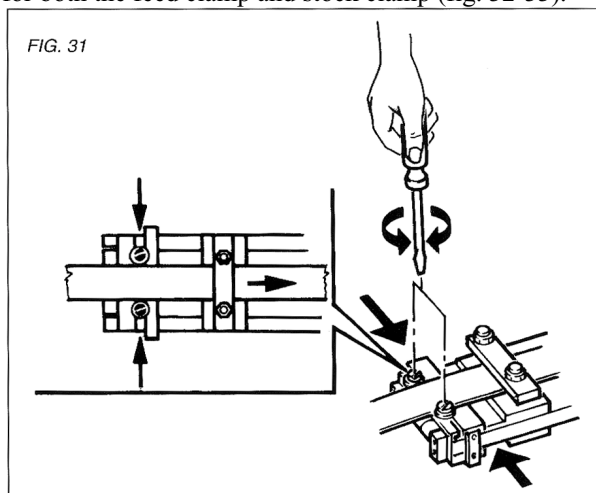

FIG. 31

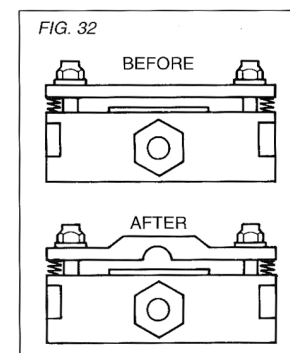

FIG. 32

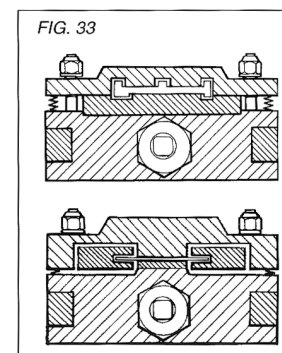
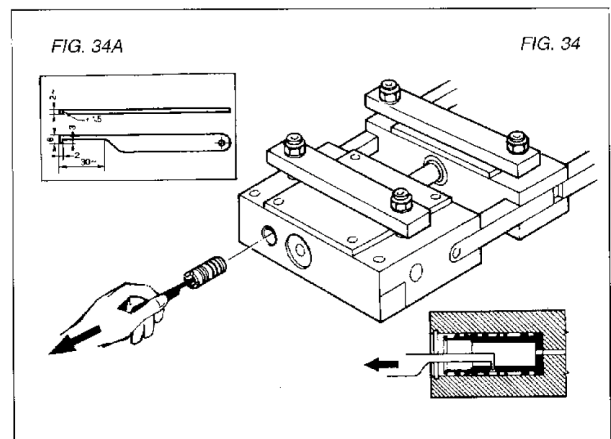

FIG. 33

14-REMOVING OF THE SECONDARY VALVE

TYPE A-B-C- (fig. 34-35)

- Using suitable pliers extract the split-ring part 102.
- Extract the cover - part 5
- Carefully inject air into the feeder to extract part 7 and part 8.
- Introduce the special tool built as per fig. 34A into the valve body and insert the hook into one of the holes in the valve.
- Exercising a little pressure outwards, extract the valve body part 6. For the assembly you have to reverse this process. Attention: it is necessary to lubricate the seal rings before inserting the valve body. During the assembly part 8 must be inserted with the slot in the front position (fig. 35).



TYPE BX-CX-DX-SX-ZX-P-S-TZ-V-K-2TV-2TK (fig. 40-41)

- Using suitable pliers extract the split-ring part 102.
- Extract part 5T (in case of feeders with more than one cylinder there are 2 valves 6T).
- Carefully inject air into the feeder.
- Part 7T comes out (fig. 36).
- Introduce the special tool in the holes of valve 6T (see fig. 37) and extract the valve body 6T. Also use circlip pliers pulling out and gently rotating the piece. (fig. 37A). For the assembly you have to reverse this process. Attention: it is necessary to lubricate the seal-rings before inserting the valve body.

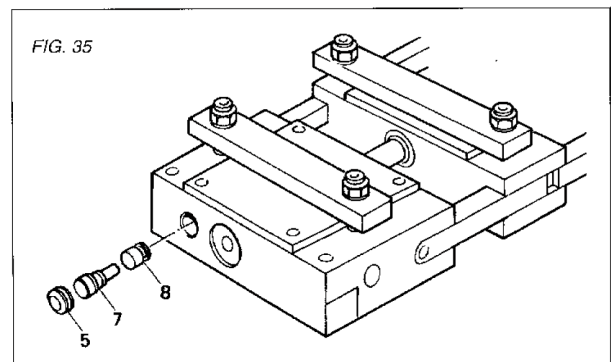

Important note: if you wish to let part 7T come out of body 6T, blow air from the little hole on part 6T; see fig. 37B.

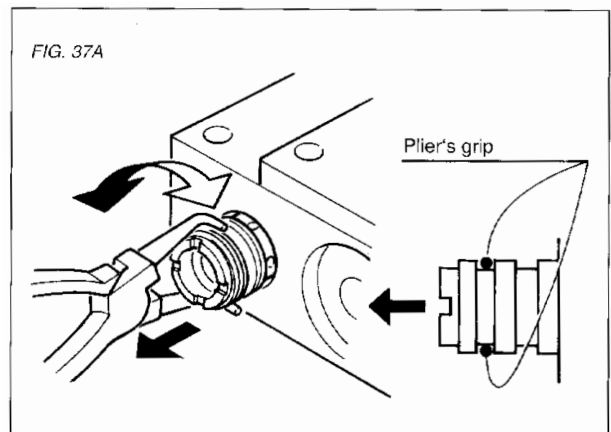
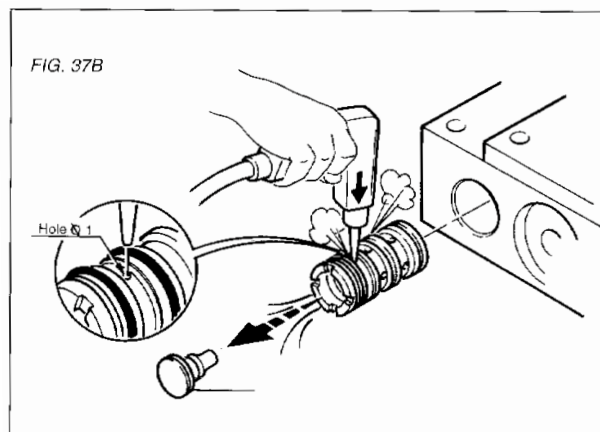
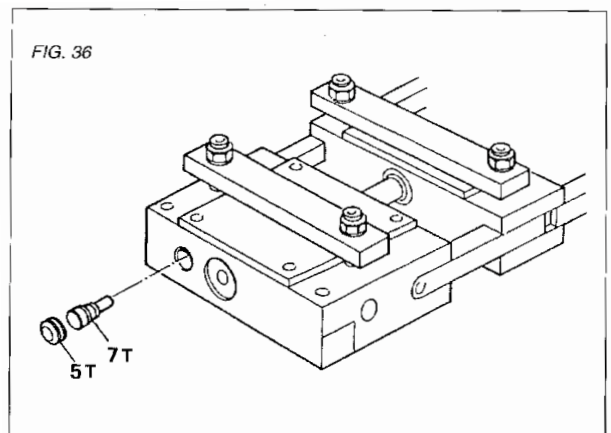
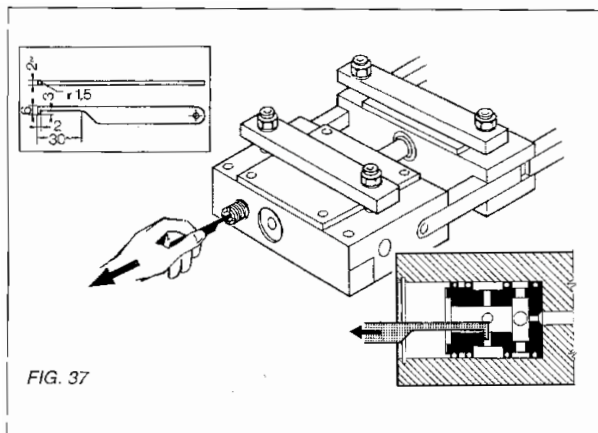

15-REMOVING THE MECHANICAL VALVE

- a) Using suitable pliers remove the split-ring part 103 from its site.
- b) Extract part 25 + 24 + 23 + 22 and o-ring 73.
- c) With a suitable hook tool (fig. 38B) inserting the hook in the hole in part 26, extract part 26 (see fig. 38).

For the assembly you have to reverse this process.

Attention: fit o-ring 73 like fig. 38A; do not fit it in the air-discharger slot.

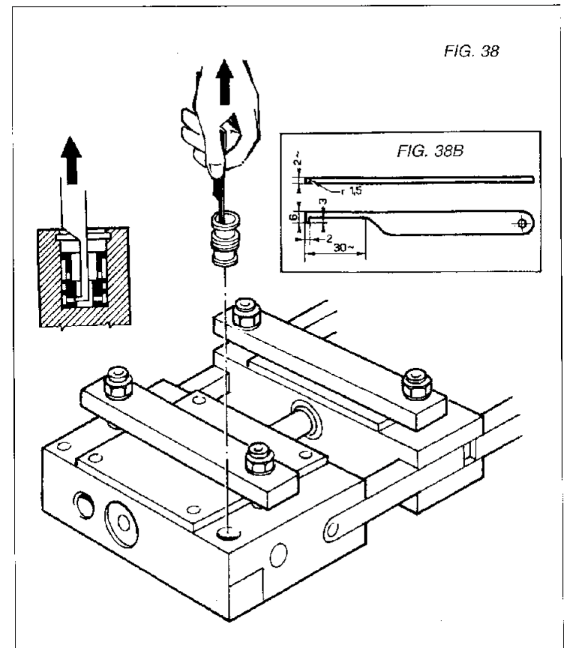
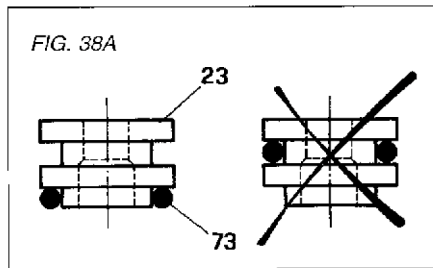

16-REMOVING THE CHROMIUM PLATED MAIN PISTON PART 14 + 15

TYPE A-B-C; BX-CX-DX; P-S-Z; TZ; V-K; 2TV-2TK

- a) Remove the stock block 4, by taking away the keys part 34.
- b) Remove the circlip 104 and consequently part 9 + 10 (in case of more than one cylinder feeders there will be more than one part 9 + 10).
- c) By using the appropriate pliers extract circlip 105 from its position (in case of more than one cylinder feeders there will be more than one part 105).
- d) Extract the whole mobile clamp block.
- e) Put the whole mobile clamp block in a vice to unscrew part 17 with an allen wrench as follows:
type A-B-C by wrench mm. 27; type BX-CX-DX-SX-ZX by wrench mm. 32; type PSZ-TZ-K by wrench mm. 36. On some feeder's types there are some white plastic washers part 50 inside of part 17, that must be removed and assembled following our exploded view. On the feeders type P-S-Z the middle part 17 contains part 16C/B + 16D/E for the rapid air-exhaust. They must be assembled and disassembled following our exploded view.
- f) Using a rubber hammer strike at the cylinder's head part 14 (on some models there is more than one cylinder). The cylinder will extract from the rear end.
- g) To unscrew part 16 from part 15, use two wrenches, one to unscrew part 16, the other one to avoid the rotation of part 15 (fig. 39). This regards feeders type ABC; BX; CX; DX; SX; ZX. Type A-B-C wrench mm. 21 + mm. 14. Type BX; CX; DX; SX; ZX wrench mm. 26 + 14. On the feeders heavy duty series (P-S-Z; V; TZ; K; 2TV; 2TK) insert one rod in the hole on the cylinder and one in part 16's hole to unscrew the two parts (see fig. 40). Attention: for security reasons we put a cyano-acrylic adhesive on part 16.
- h) Then extract part 14 + 15 from the front of the mobile clamp. Do all the gaskets replacements operations on part 12 and 13 and reverse this process for the assembly.

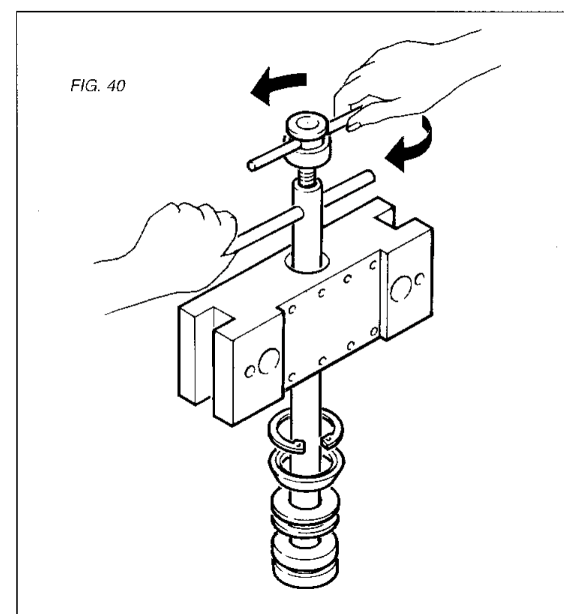
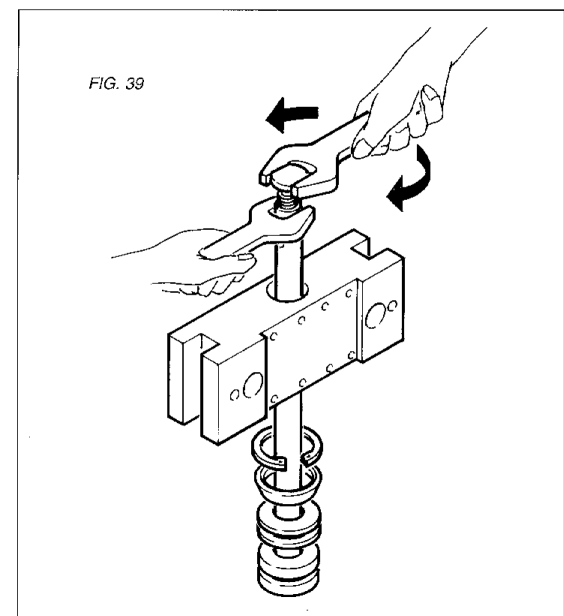

**CHARACTERISTICS AND POSSIBLE CAUSES OF TROUBLES WITH
DURANT/HERRBLITZ AIR FEED**

<i>Characteristic</i>	<i>Possible Cause</i>
1. Feed and Stock Clamps work, but slide block does not move when actuating valve is depressed.	a. Pilot Operated Valve is stuck, either by grit, swollen nylon, or “O” Rings.
2. Excessive leakage of air from exhaust hole, beneath speed adjusting screw when actuating valve is in up position.	a. Poppet not seating on bottom of valve hole- check for grit or chips. b. Leaking of “O” Rings. See assembly drawing for location.
3. Excessive leakage of air from exhaust hole, also sluggish operation of feed clamp pistons. Actuating valve is up.	a. Leaking “O” Rings #62, # 64, #65, # 68, #69 parts, 6, 8. See assembly drawing for location.
4. Excessive leakage of air from exhaust hole when actuating valve is in down position. (Note that a slight amount of leakage is normal in this position).	a. Tight “O” Rings or grit around pilot operated valve may prevent it from moving its full stroke. b. Worn Poppet.
5. Stock Clamp does not move up and down when actuating valve is depressed. Other operations appear normal.	a. Worn “O” Ring around O. D. of Stock Clamp Pistons.
6. Excessive leakage of air from actuating valve vent hole when actuating valve is in up position. in	a. “O” Ring beneath actuating valve retainer is leaking. Install “O” Ring beneath retainer-not air groove. See Assembly drawing.
7. Gradually reduced speed.	a. Lack of oil. b. Low viscosity oil. c. Speed adjusting screw turned in too far. d. Oversized Poppet.
8. Excessive leakage of air from pilot operated valve vent hole on side of feed.	a. Leaking of “O” Rings around pilot valve. See Assembly drawing.
9. Cushion Pistons act too slow and provide too much cushion.	a. Excessive oil, reduce supply.
10. Mist of oil coming from exhaust hole.	a. Excessive oil, reduce supply.

11. Feed has difficulty pushing last part of progression.

a. Feed is not in line with die. A slight angular adjustment of the feed will reduce the binding of the stock on the die guides.

12. Under feeding.

a. Insufficient air pressure.
b. Feed is not in line with die.
c. Stock Clamp and feed clamps are loose.
d. Feed is not lubricated.
e. Stock excessively dirty, dirt may be present between slide block and main body.
f. Feed may be feeding before punches are clear from stock or die. Adjust amount of depression of actuating valve.
g. Feed may be operating too slow. Turn speed adjusting screw counterclockwise to increase speed.
h. Cambered stock. Use special stock clamp.

13. Over feeding.

a. Stock is excessively dirty or oily.
b. Feed is operating too fast. Turn speed adjusting screw clockwise to slow down.
c. Stock has large slitting burr. Check clearance between clamps and stock.
d. Stock and feed clamps may be loose.

14. Slide goes back and stays.

a. Small "O" Ring from E valve, on end of actuating valve.

15. Slide block actuates back and forth very fast when actuating valve is depressed.

a. "O" Ring around control tube and inside main piston, cut loose or badly worn.

16. Feed clamps not releasing before sliding back.

a. Springs are weak, broken, or wrong ones.
b. "O" Rings badly swollen.
c. Clamps badly grooved.

17. Slide blocks slow to react.

a. Possible small "O" Ring for E valve is on mechanical actuation.

18. Snap rings on pilot operate valve being pushed out, especially on larger feeds.

a. Low volume of air.

19. Feed clamps not releasing before slide blocks return to rear.

a. Main actuating is being hit at a slant rather than directly on top. (This true mostly in larger feeds).

20. Cannot slow feed down with the adjusting screw.

a. Small "O" Ring on the pilot operated valve is missing or torn.